

Installation and Operating Manual for



2009-2014

NCB-120-COAL
NCB-175-COAL
NCB-250-COAL
NCB-275G-COAL
NCB-325G-COAL
NCB-400G-COAL

Non-Pressurized Outdoor Coal Boiler
Manufactured by Nature's Comfort LLC.

Made in the USA

www.naturescomfortllc.com

Built Like A Tank
With Laser Precision

SAVE THESE INSTRUCTIONS

INTRODUCTION

Thank you and congratulations on the purchase of your new Nature's Comfort boiler!

With the purchase of this Nature's Comfort boiler, you can now appreciate the high degree of craftsmanship and reliability that are a result of every boiler being carefully hand-built as well as taking control of heating your home. Your choice shows the recognition you have for high quality products.

We deem it important to provide you with this operation and maintenance manual, allowing you to use your equipment under the best possible conditions and in the most optimal manner and furthermore, to increase its operating life. **Read through carefully before beginning installation, follow all instructions and keep this manual handy.**

THIS MANUAL INCLUDES IMPORTANT SAFETY INFORMATION ON PAGE 5

Again, thank you for purchasing a Nature's Comfort Boiler.

We appreciate your business!

If you are in need of insulated pex, heat exchangers or other parts for your new boiler call your dealer or call us at 877-251-7740 for the lowest prices!

Boiler water treatment and test required at time of installation and annually to validate warranty. See warranty page for complete details.

Visit www.naturescomfortllc.com each year to confirm the most up-to-date installation, operation & warranty information or if you need to see any page in color.

Please keep this manual with all other important papers. The information in this manual is necessary for the installation, operation and proper use of the boiler. If you should ever have a problem or question refer to this manual or call your dealer. If your dealer does not have the information you need, request they contact Nature's Comfort and your dealer will be further educated to provide the best possible customer service. Please keep in mind that Nature's Comfort built the boiler but did not install it and has no control over the installation, the efficiency of the building's insulation or what is burned in the boiler.

Table of Contents

I. General Information

A. Terminology.....	6	D. Safety Precautions.....	7
B. Clearance to Combustibles Required.....	6	E. Controls & Plumbing Connections.....	8
C. Boiler Dimensions & Specs.....	6	F. Heating the Home.....	9

II. Installing the Boiler

A. Location of Boiler.....	10	I. Installing In A Small Plenum	15
B. Chimney, Extensions & Rain Cap	11	J. Adjusting Plenum Air Flow.....	16
C. Underground Insulated Pex Pipe.....	11	K. Installing On An Existing Indoor Boiler	16
D. Plumbing Hookup.....	12	L. Filling The Boiler with Water.....	19
E. Wiring the Boiler	12	M. Float Level.....	19
F. Forced Air Systems -Thermostat Wiring.....	12	N. Bleeding Air From Heat Exchangers	19
G. Adding Bypass Valves	14	O. Pre-conditioning Rope Seals.....	19
H. Installing A Water-To-Air Heat Exchanger.....	14		

III. Heating Domestic Water, Pools and Spa's

A. Sidearm Or Plate Heat Exchanger For Domestic Hot Water	20
B. Heating a Pool or Spa	21

IV. Operation

A. Coal Requirements.....	22
B. Starting A Fire	22
C. Loading Coal.....	22
D. Blower Output Damper.....	23
E. Power Loss Procedure, Running On A Generator	23
F. Warm Weather Operation, Bypass For Domestic Hot Water Only	23

V. Maintenance

A. Cleaning.....	24
B. Disposal Of Ashes	24
C. Creosote – Formation And Need For Removal.....	24
D. Fuel Door & Cover Seals	24
E. Pump.....	25
F. End of Season Care	26

Going Away.....	27
-----------------	----

Disclaimer	27
------------------	----

Trouble Shooting	28
------------------------	----

Warranty	29
----------------	----

Warranty Cards.....	30
---------------------	----

I. General Information

A. Terminology In This Manual

Boiler: Refers to the Nature's Comfort boiler.

Furnace: Refers to the existing indoor gas or oil fired unit which heats the air or radiant water heat for the home.

B. Clearance to Combustibles Required

Top, Front, Rear and Sides: 36"
Flooring: Non-Combustible

C. Boiler Dimensions & Specifications

NCB-120 COAL	160,000 BTU, 120-gallon water tank, 3,000 sq ft.* 42"x63"x86" tall, 1652 lbs
NCB-175 COAL	220,000 BTU, 175-gallon water tank, 4,000 sq ft.* 46.5"x60"x90" tall, 1817 lbs (3/8" firebox)
NCB-250 COAL	300,000 BTU, 250-gallon water tank, 6,000 sq ft.* 46.5"x78"x90" tall, 2260 lbs (3/8" firebox)
NCB-275G COAL	400,000 BTU, 275-gallon water tank, 8,000 sq ft.* 50"x73"x89" tall, 2113 lbs
NCB-325G COAL	460,000 BTU, 325-gallon water tank, 10,000 sq ft.* 50"x85"x89" tall, 2313 lbs
NCB-400G COAL	500,000 BTU, 400-gallon water tank, 12,000 sq ft.* 50"x85"x96" tall, 2613 lbs

*Will heat up to (x)sq ft (This must include all heated areas of home as well as basement.) with proper installation, properly insulated building and when dry coal is used.

Deduct a minimum of 500 sq ft if heating domestic hot water.

Firebox Sizes

Model (Coal)	Cu/Ft	Description	Width	Depth	Opening	Ash Pan
NCB-120	15.0cu/ft	oval	25.5"W x 31"H	36"	21.75"W x 22"H	39" X 11.75"X 4"
NCB-175	13.5cu/ft	29" cylinder	29.25"	36"	25.75"W x 17.75"H	39" X 11.75"X 4"
NCB-250	20.5cu/ft	29" cylinder	29.25"	54"	25.75"W x 17.75"H	39" X 11.75"X 4"
NCB-275G	23.4cu/ft	oval	30"Wx36"H	42"	27"W x 25.5"H	39" X 11.75"X 4"
NCB-325G	28.5cu/ft	oval	30"Wx36"H	54"	27"W x 25.5"H	39" X 11.75"X 4"
NCB-400G	40.0cu/ft	oval	30"Wx46"H	54"	27"W x 25.5"H	39" X 11.75"X 4"

Steel thickness

Model (Coal)	Water Jacket	Firebox
NCB-120	10ga. (approx. 1/8")	1/4"
NCB-175	7ga. (approx. 3/16")	3/8" or 1/4"***
NCB-250	7ga. (approx. 3/16")	3/8" or 1/4"***
NCB-3275G	7ga. (approx. 3/16")	1/4"
NCB-325G	7ga. (approx. 3/16")	1/4"
NCB-400G	7ga. (approx. 3/16")	1/4"

***Firebox thickness depends on option ordered by customer

D. Safety Precautions

Do not operate this equipment for anything other than its intended purpose or for anything other than in accordance with the instructions contained in this manual and all other instructions accompanying the boiler. It is important to observe safety precautions to protect yourself and others from possible injury. Observe all safety labels on the boiler.

All electrical and plumbing should be done by qualified personnel and conform to national, state and local electrical, plumbing, fire and building codes.

1. DO NOT USE CHEMICALS OR FLUIDS TO START THE FIRE. Never use chemicals or any type of petroleum based product, charcoal starter, lighter fluid, lantern fuel, kerosene or any other flammable accelerant to start the fire in the firebox of the boiler. Keep all such liquids well away from firebox.
2. If using antifreeze, use only non-toxic, follow manufacturer's recommendations on mixing ratio and test annually per manufacturer's specs. Keep containers of antifreeze, which is flammable, well away from the boiler.
3. The use of treated wood (painted, treated, etc.) and any other salvaged material that can emit toxic gases into the environment and is corrosive towards the components of the appliance is not allowed and voids the warranty.
4. DANGER! Risk of fire or explosion – DO NOT BURN GARBAGE, GASOLINE, NAPHTHA, ENGINE OIL OR OTHER INAPPROPRIATE MATERIALS. Flammable liquids household or yard waste can reduce the life of the boiler, will void the warranty and is illegal in most areas.
5. Pause for 30 seconds between the first latch and the safety latch to allow any combustion gases to burn off. Always keep fueling and de-ashing doors closed and maintain all seals in good condition.
6. In the event of a runaway fire, make sure all doors are tightly shut, unplug the control power, keep the pump running, make sure the blower damper is closed and keep the water jacket full.
7. WARNING! Risk of fire – Do not operate with fuel loading door open. Do not store fuel or other combustible material within the marked installation clearances. Leaving a small crack or opening can cause over-heating in the firebox, boiling the water off, damage of the unit and voiding the warranty. Inspect and clean the firebox, ash pan and chimney regularly.
8. CAUTION! Hot surfaces. Keep children away. Do not touch during operation. Always use proper care when installing, operating and maintaining the boiler.
9. Always wear protective gloves and glasses and be aware that hanging and loose clothing can catch fire.
10. All doors and covers must be maintained in place at all times, except during maintenance and servicing.
11. Do not modify the boiler or controls. Do not connect this unit to a chimney flue serving another appliance.
12. Failure to heed these warning or any additional warnings on the boiler may result in an accident causing personal injury and damage and void the warranty.

All installation and operation must follow federal, provincial, state and local codes

E. Controls & Plumbing Connections

The outside boiler has a hot water thermostat (aquastat) with a thermocouple that is inserted into a brass drywell that senses the water temperature of the unit. When the temperature of water in the boiler falls below the "low" temperature setting on the aquastat, the solenoid lifts the cover off the blower which turns on, feeding oxygen to build a hotter fire and remains on until the water temperature in the boiler reaches the "high" temperature setting of the aquastat.

Temperature should be set at 180F and no higher with the differential setting at 15 degrees. This provides for an "on" point of 165F and a long burn cycle to burn off any creosote buildup. Running below 150F at any time will result in condensation from too great of a temperature difference between the water jacket and firebox (same principle as a glass of ice water left out on a hot day) which increases creosote and when mixed with ash is very corrosive and will shorten the life of your boiler.

Boiler shown is set up as a single-zone. You may install fittings to have ports for up to 4

ZONES (Consult your dealer. Additional port setups with pumps are also available from Nature's Comfort when ordering a new unit.)

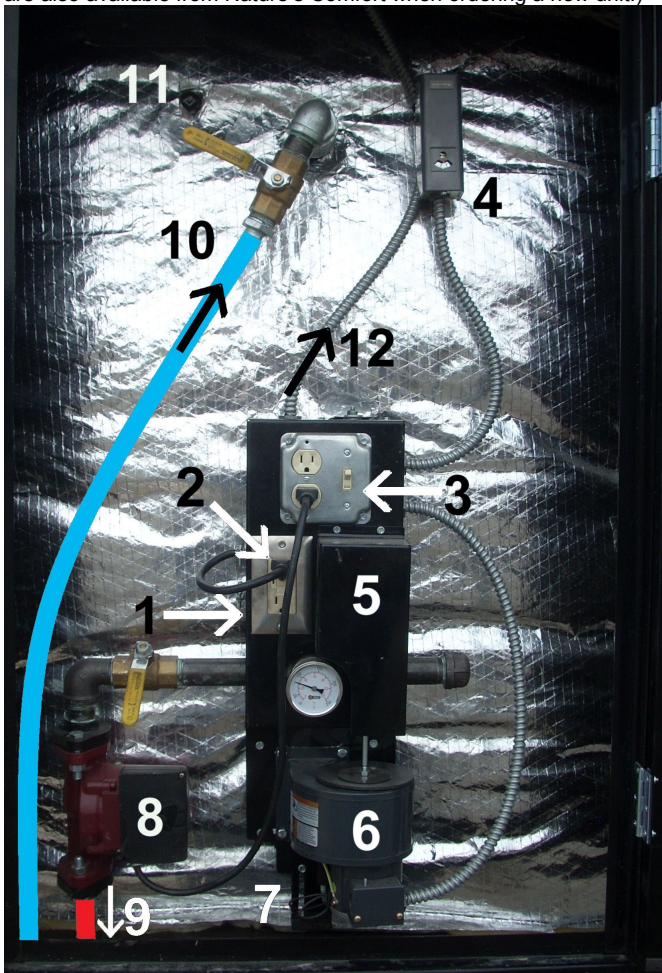

Single-Zone setup

1. Power from home feeds lower outlet
2. Control power for pump, aquastat, solenoid, blower and light is fed through main plug by lower outlet.
3. Switch for shutting off power to aquastat (which will shut down blower & solenoid).
4. Aqua-stat sensor for controlling blower and solenoid.
5. Solenoid (behind cover) to lift intake cover off blower.
6. Blower to feed oxygen to fire.
7. Damper to control air flow.
8. Pump to circulate water. (One pump is included.)
9. Red Pex pipe goes from the pump to heat exchanger(s) in home. **Please note! The pump that came with your boiler may not be the correct size for your installation. Please consult your dealer for sizing as water flow is essential to the proper & efficient operation of your installation.**
10. Blue Pex pipe returns from home to upper port. (Use of additional valve is recommended for ease of servicing. Not included.)
11. Extra Port (This is for a low water cut-off switch if required by an inspector. Call your dealer to obtain if needed)
12. Wires to outdoor light. (If applicable – may be provided with solar rechargeable LED light)

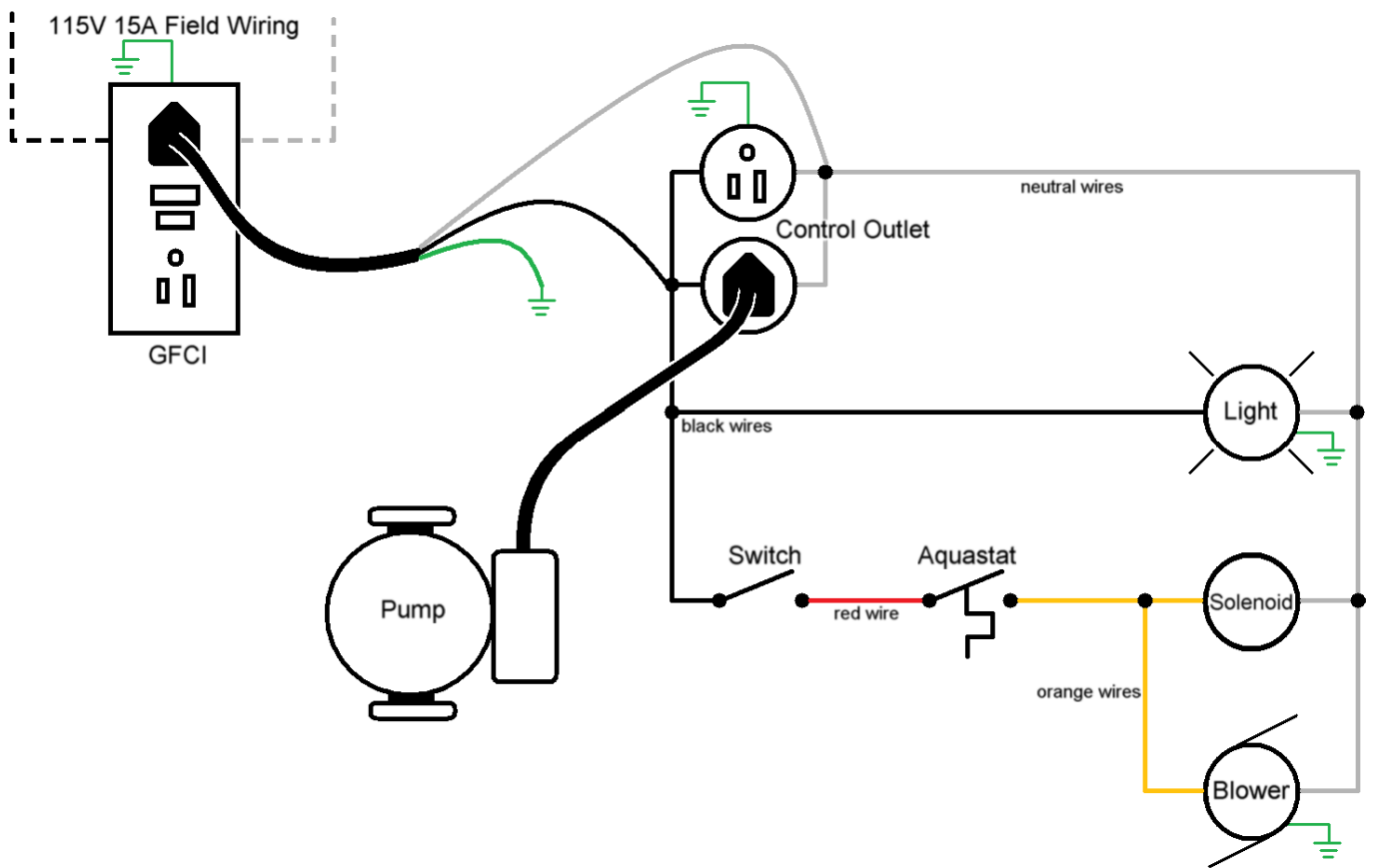

F. Heating the Home

The NCB boiler saves energy and provides the most comfortable heating available. It heats the home by burning seasoned hardwood to heat a firebox surrounded by a steel tank filled with water. The boiler is non-pressurized with an atmospheric vent and includes an easy-to-read water jacket float indicator. The heated water must be circulated through insulated underground pex pipes to a heat exchanger that must be installed in the existing furnace system.

If you have a forced-air system, a water-to-air heat coil must be installed in the ductwork. When air travels through, heat is extracted and hot air is emitted out of the registers.



A water-to-water plate heat exchanger must be used if you have a hydronic radiant heating system. When connecting to an in-floor heating system in concrete, a mixing valve is also required to keep temperatures below 110F or damage to the concrete will occur over time from too much heat expansion.



Complete parts packages at the lowest prices are available from Nature's Comfort or your dealer!

III. Installing Boiler

Installation is to be performed by a qualified installer and shall comply with all the requirements of the authority having jurisdiction over the installation.

A. Location of Boiler

The NCB boiler must be located to comply with the clearance requirements. Keep the firebox door positioned so as not to point toward a structure so all fire danger is removed from the home. The boiler may be installed as much as 250 feet away using an appropriately sized pump and piping and still heat the house and hot water. However, if the boiler is located more than 100 feet away, you may experience inefficiency and heat loss. A larger pump than the one supplied may be needed for distances over 100 feet and/or any rise in elevation over 15 feet.

Locate the NCB boiler where it will be convenient for refueling and coal storage. Pex pipe and power lines are to be installed underground between the house and the boiler and must be buried below frost lines.

1. It is recommended that the boiler be installed with chimney extensions for due consideration to any neighboring residences and to the prevailing wind direction.
2. Do not locate the boiler within 100 ft of a residence not served by the boiler. Be considerate of neighboring residences, properties, parks, etc.
3. Do not locate the boiler near any combustible materials, gasoline or other flammable liquids or gases.
4. The boiler should be located away from dry, grassy areas and any buildings to minimize danger of fires.
5. Check with the insurance company and local codes or ordinances.
6. Do not install the boiler in an area where nearby structures or trees might cause down drafts.
7. Typically, outdoor coal burning boilers are located 40 to 100 ft down wind from the structure served.
8. To aid in smoke dispersal, extra chimney lengths may be required depending on the distance to surrounding structures.

Failure to keep the boiler area clear and free of combustible materials, gasoline and other flammable liquids and vapors can result in severe personal injury, death or substantial property damage.

A full concrete pad or footings just under the feet are not necessary for the installation for the boiler, but is recommended to prevent frost heaving. Four concrete footing blocks 8" X 16" X 4" will suffice if desired. You may add additional layers of blocks for ease of loading coal. The figure below is for outside foot dimensions.

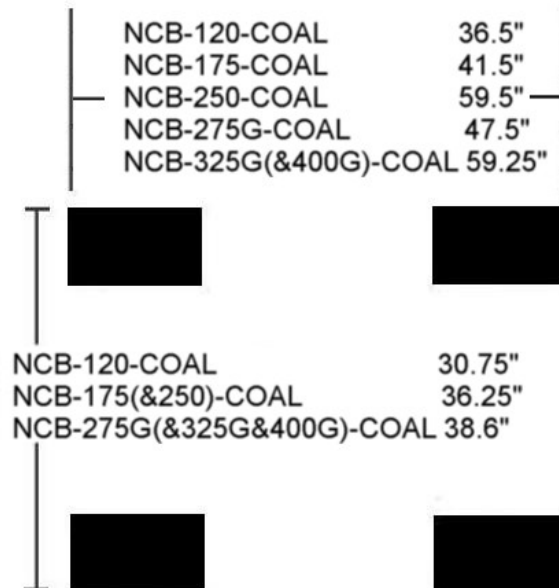

If the unit is located in a windy area, it is recommended to install a non-combustible type of skirting around the feet and control area.

B. Chimney:

A stainless steel rain cap (5" for 120 model, 6" for 175, 250 & 325G) must be purchased separately for installation and can be obtained from Nature's Comfort or your dealer. If installing extensions, use supports as directed by pipe manufacturer. It is recommended that the boiler be located with due consideration to the prevailing wind direction.

- 1 It is recommended that the stack be at least 2 feet higher than the peak roof line the nearest residence.
- 2 If located more than 100 feet but no more than 150 feet to any residence, it is recommended that the stack be at least 50% of the peak roof line of that residence, plus an additional 2 feet.
- 3 If located more than 150 feet but no more than 200 feet to any residence, it is recommended that the stack be at least 25% of the height of the peak roof line of that residence, plus an additional 2 feet.

Example of chimney height relative to nearest downwind neighbor

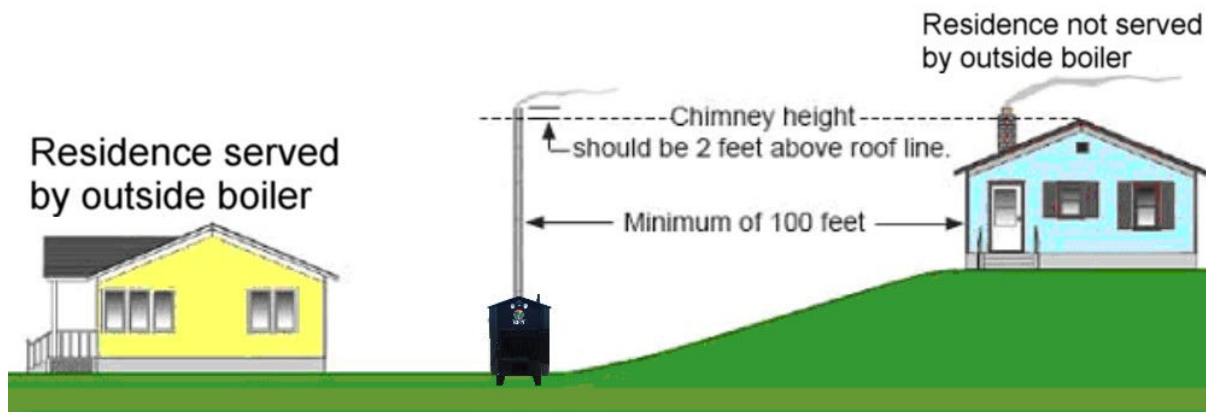

Always comply with all applicable state and local codes and laws.

C. Underground Insulated Pex Pipe

You must use underground insulated pex pipe for transferring the heated water from the boiler to the home. Minimum pipe size permitted is 1". Platinum 3 wrap (4" drain tile) & Platinum 4 wrap (5" drain tile) insulated pipe is available for purchase through Nature's Comfort or your dealer. It may contain twine for pulling electrical wire. If possible, do this with the pipe laid out straight for ease of pulling.

CALL YOUR LOCAL MISS DIG HOTLINE BEFORE YOU DIG TRENCHES!

Bury the underground insulated pipe below frost lines (or just above water table level) and keep underground as it enters the house. The depth of the trench varies in different regions of the country. Be completely sure about the correct depth needed before the insulated pex pipe is installed underground. Contact your local building inspector's office for this information. Make sure to seal around the corrugated pipe to prevent water from entering. If conditions require the pipe to be above ground for entering the home, make sure to insulate thoroughly.

Note: If only one color of PEX pipe is used, label the water lines or connect and test them before back filling over pipe and lines. If you have rocky ground, make sure you use clean fill or place straw or landscape fabric around the pipe before back filling, giving extra protection against punctures.

If more than one building is to be heated, additional pipe and pump must be installed.

D. Plumbing Hook Up

Plumbing connections should be well insulated after installation. Cover bottom access holes as well.

Minimum pipe size permitted is 1". Install the outgoing pex line on the pump flange that is already mounted to the lower end of the circulation pump. Install the return line on the 1-1/4" fitting located in the top-middle of the rear control area. **Add a valve to the return line so if repair or service is needed on lines or equipment, the water in the boiler can be isolated without having to be drained.** (Valves and PEX fittings can be purchased from Nature's Comfort or your dealer.)

Install a fill line from the domestic water into the return line at the house using a T, 2 valves and a union to disconnect or a backflow preventer when not using to keep 100% isolated so no boiler water can ever enter the domestic side if pressure is lost.

Use sweeping bends for PEX pipe keeping 90's to a minimum (no more than 6) as each one adds 1 foot of head pressure, reducing the rate of water flow. For tight radiuses use 3/4" rubber heater hose in short lengths (fits 1" PEX fittings and is available from Nature's Comfort or your dealer).

For a forced air system, run the line from the pump first to the heat exchanger for the domestic hot water then to the one in the furnace plenum. For a hydronic radiant system, reverse this order.

Note: For larger homes, 1-1/4" pipe may be needed for maximum BTU output. A 1-1/4" pipe can carry up to 37% more BTUs due to higher water flow. The fittings above would need to be changed to accommodate 1-1/4" Pex. The Armstrong E9.2 pump available from Nature's Comfort or your dealer has the ability to do this in a 1" pipe within distance & height limitations.

E. Wiring the Boiler

A qualified electrician must wire this boiler in accordance with the National Electrical Code.

A dedicated GFCI protected 15amp, 115vac circuit needs to be installed to power the lower outlet. Land power & neutral wires to the back of the outlet and wire nut the ground wire to the green wire that is fastened alongside the ground of the outlet. See controls section for an electrical diagram.

The size and type of electric wire to be installed depends on the distance from the boiler to the house. If the boiler is less then 100 feet from the house, #14 AWG UF cable is the smallest wire that may be used. If the distance is greater than 100 feet, #12 AWG UF cable must be used.

A maximum of 5 amps is used by the boiler if all standard equipment is running. The extra outlet will provide a total of 10amps for convenience use.

For ease of loading at night, it is suggested to install an outdoor light on a pole, 10'-20' from the front of the boiler and offset slightly so a user can see inside the firebox when loading.

F. Forced Air Systems - Thermostat Wiring

The next example drawings are for controlling the blower on a forced air system independently of the existing heat source (i.e. propane, electric, fuel oil, etc). Nature's Comfort can provide custom diagrams for other types of control setups as well upon request.

Use this example diagram if you have a typical, basic 4 wire system:

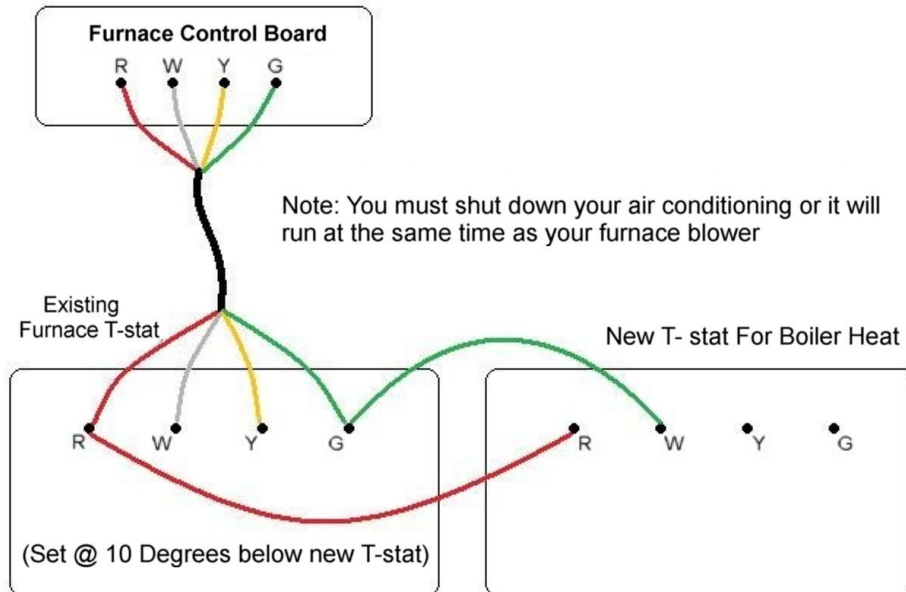

Use the example drawing below if you have a 2 wire system or the thermostat is the advanced computerized type that communicates back and forth between the furnace (typically found on heat pump systems). **Do not use this method if your HVAC system utilizes a multi-speed blower.** All of the parts below are available through your dealer or Nature's Comfort.

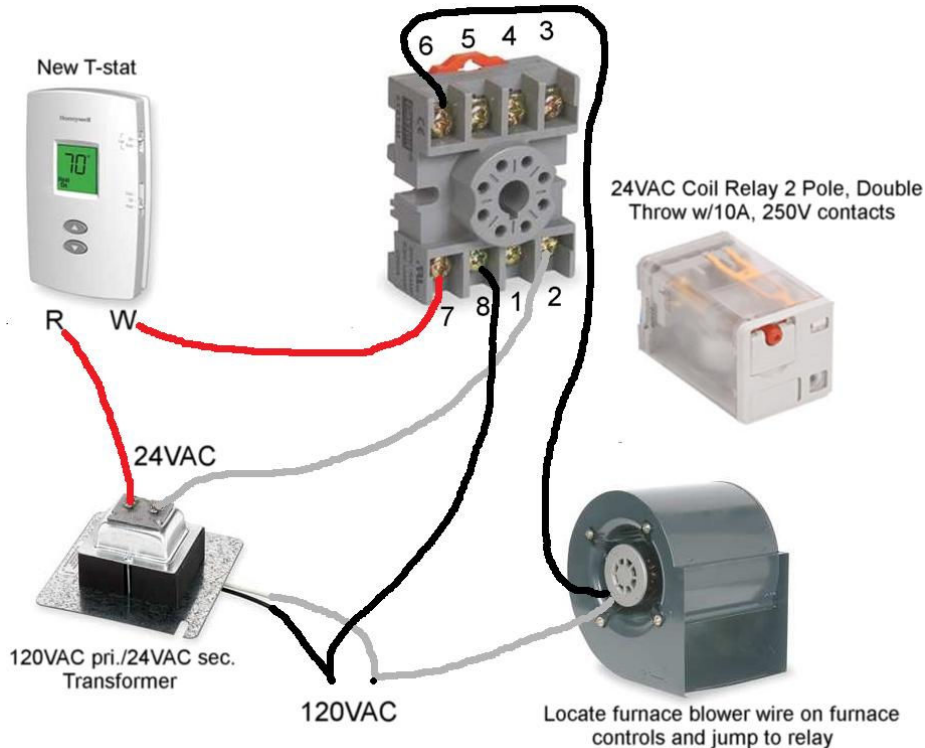

G. Adding Bypass Valves

Adding a bypass valve system (3 valves, 2 T's and unions) at each heat exchanger is a good idea so that if there is a potential problem such as a stopped up heat exchanger, it can be diagnosed & serviced easily as well as being used for a summer bypass as explained in the "operation" section of this manual.

H. Installing A Water-To-Air Heat Exchanger

The heat exchanger should be installed above an air conditioning condenser coil and must be placed at least 2" above it so any ice that may form on the condenser due to improper operation won't touch the new heat exchanger.

No air can be allowed to flow around it or out of the ductwork. Use adhesive backed foam tape (used for insulating doors and windows) to seal around the frame and foil tape to seal off the opening you make in the plenum heat for the heat exchanger.

Make sure the fittings for the supply and return lines are easy to get to once the heat exchanger is installed.

You should be able to find a heat exchanger to fit most popular sizes of plenums. If you are unable to the ductwork must be modified to accept the heat exchanger. Wear proper protective gear. (gloves, safety glasses, etc...)

Measure the width of the heat exchanger (Dimension A in next diagram). Measure the thickness of the heat exchanger (Dimension C).

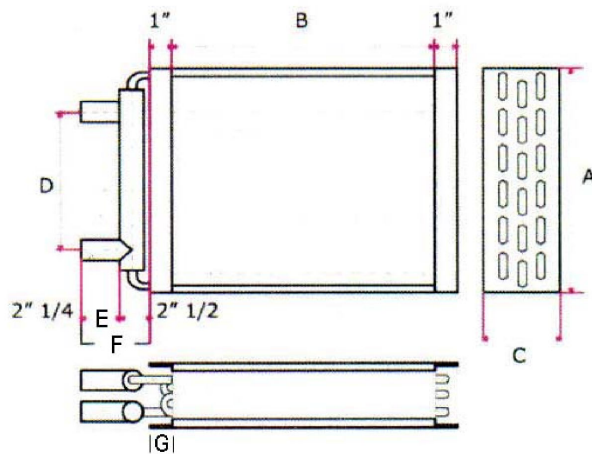

Start by cutting a hole in the side of the ductwork the thickness of the heat exchanger (Dimension C) and the full length of the ductwork (usually Dimension A).

WARNING! Metal edges are very sharp! Wear protective gloves and use caution!

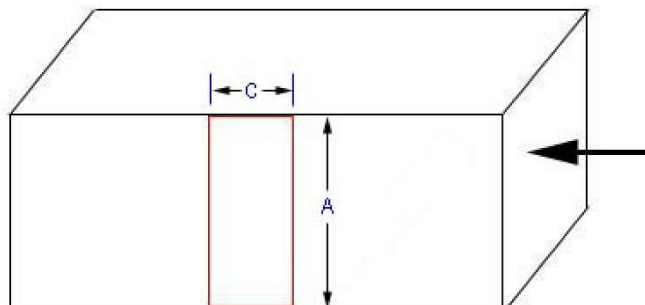

Cross section of plenum showing air blowing in it from right cut hole where red lines are.

Slide the heat exchanger into the hole for a test fit. Ideally the header and tubes (F) should stick out of the plenum.

While test fitting try to determine how much tape is needed around the frame of the heat exchanger to seal and keep air from flowing around it. A different amount (thickness) may be needed on different sides.

The heat exchanger must be secured so it won't move up or downstream in the plenum. Fabricate some 'L' shaped braces and install the proper width apart as shown below (Dimension C). Secure in place using pop rivets or self tapping screws.

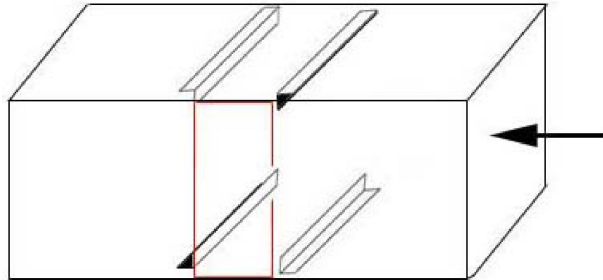

Slide the heat exchanger carefully into the plenum to check the fit again. Once proper fitting is verified, you can seal off the ends of the heat exchanger and the hole you made in the plenum with foil or duct tape.

I. Installing In A Small Plenum

You can install a heat exchanger in a plenum that is smaller than the length of the heat exchanger as follows. Make cuts at the top and bottom of the plenum, usually 4 inches long (the width of the heat exchanger) as shown below. You may need to do this on both sides of the ductwork depending on the heat exchanger size.

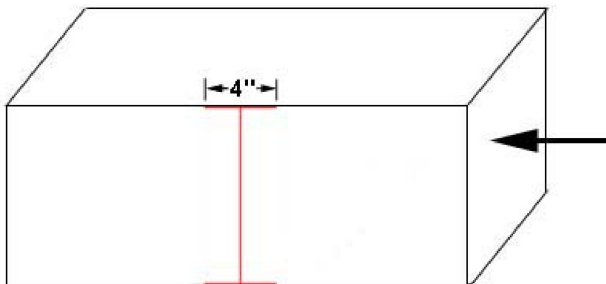

Cross section of plenum showing air blowing in it from right
Cut hole where red lines are

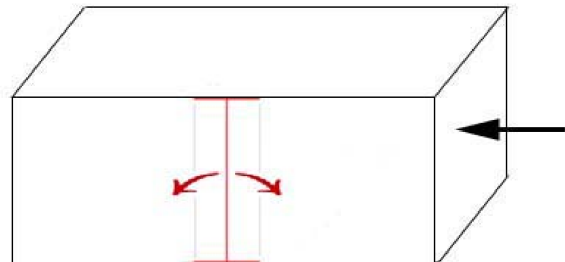

Bend the sheet metal back and out, along the grey lines.
Repeat on the back side of the plenum, in the same spot.

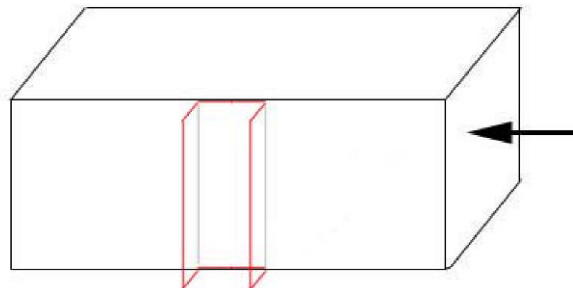

Bend the metal pieces back to slightly past 90 degrees.

Slide the heat exchanger through the front hole to the back hole so it protrudes out the front and back of the plenum the same amount. Ideally the core of the heat exchanger will be entirely within the plenum.

Crimp the sheet metal to the edge of the heat exchanger (item G) using channel-lock pliers. This not only forms a virtually airtight seal, but also supports the heat exchanger as well.

J. Adjusting Plenum Air Flow

The motors on most force air furnaces have three speeds to provide various rates of air movement. Please consult a local furnace specialist if you want to change the airflow of an existing furnace system.

K. Installing On An Existing Indoor Boiler

The NCB boiler may be connected to an existing boiler system. A water-to-water plate heat exchanger is needed to transfer heat from the outdoor boiler to the indoor hydronic system so that the two systems remain isolated (see next diagram).

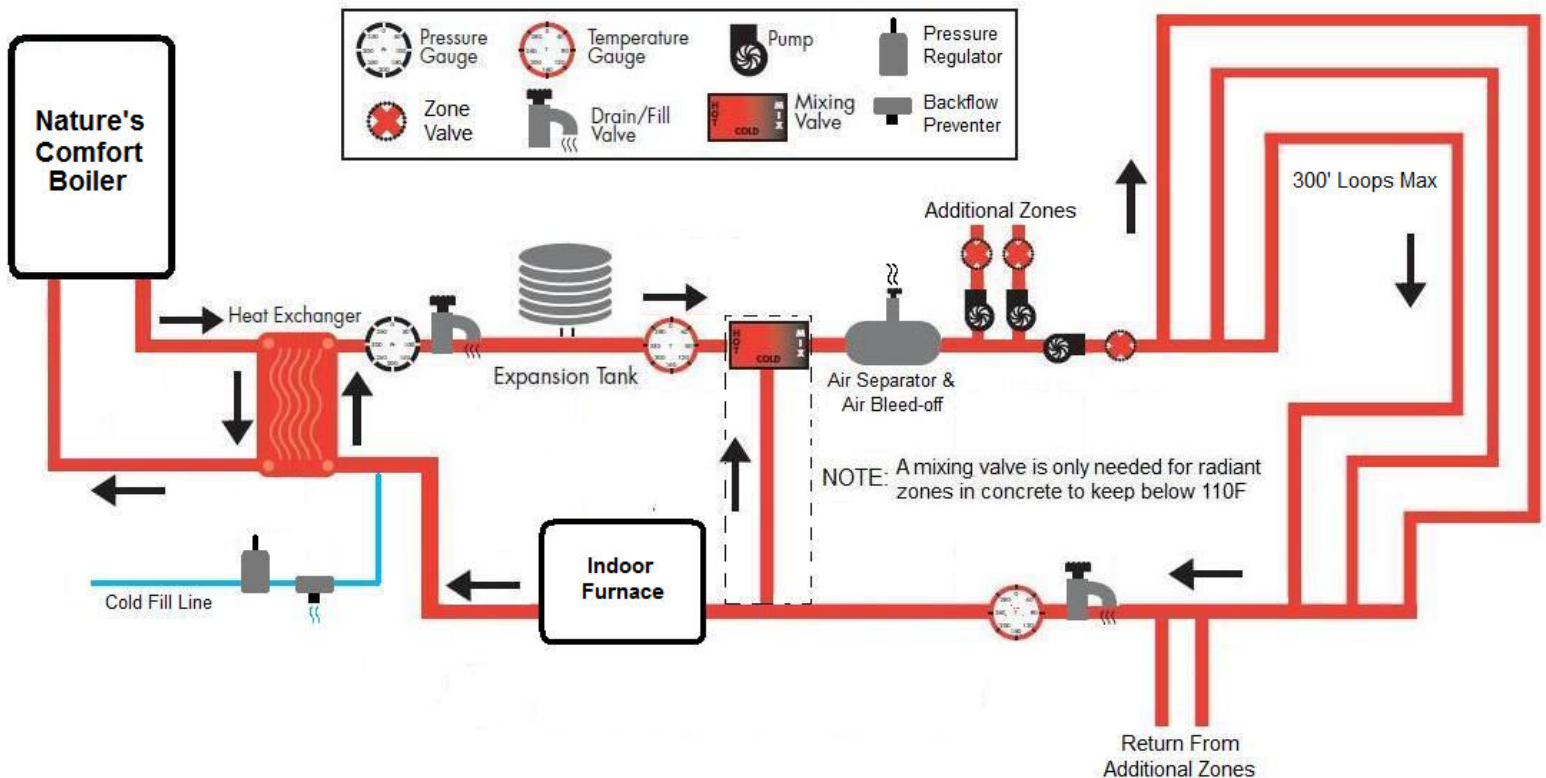

As shown in the above figure, the two systems are totally isolated from each other so that the existing hydronic system remains undisturbed and functions exactly as it did before. Water that circulates through the outdoor boiler is never circulated through the home's hydronic system or vice-versa.

All pumps and controls remain essentially the same on the existing system but you will need to keep the burner on the indoor boiler from firing. This can easily be done by strapping a thermal snap disc limit control to the incoming line from the outdoor boiler and wiring it in series with the indoor boiler's aquastat (see next drawing). This provides the means to solely heat the home with the outdoor boiler if the water on the incoming line is over 140F. If it ever falls below 120, the indoor burner will fire again to keep the home warm and also reverse heat the outdoor boiler to keep it from freezing.

Control wires for firing
burner on indoor boiler

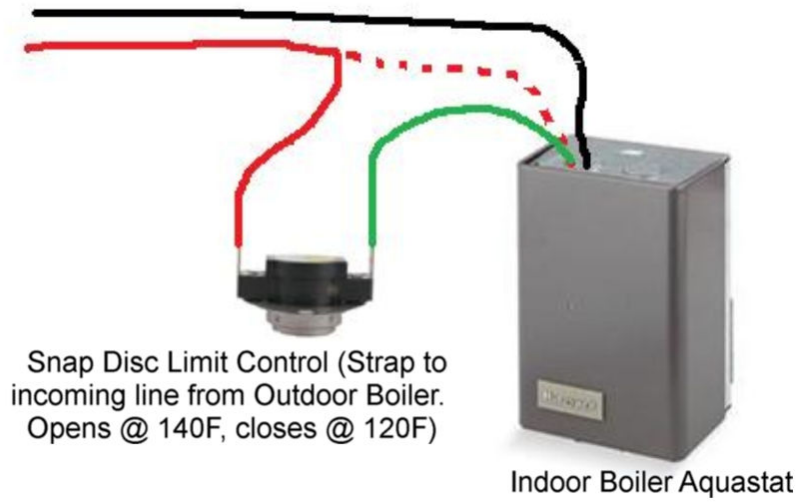

The electrical diagram on the next page shows a typical control setup for operating a 2 zone radiant system for a new radiant installation that does not use an existing hydronic furnace. Part numbers are noted on each item for ordering from Nature's Comfort.

120 VAC

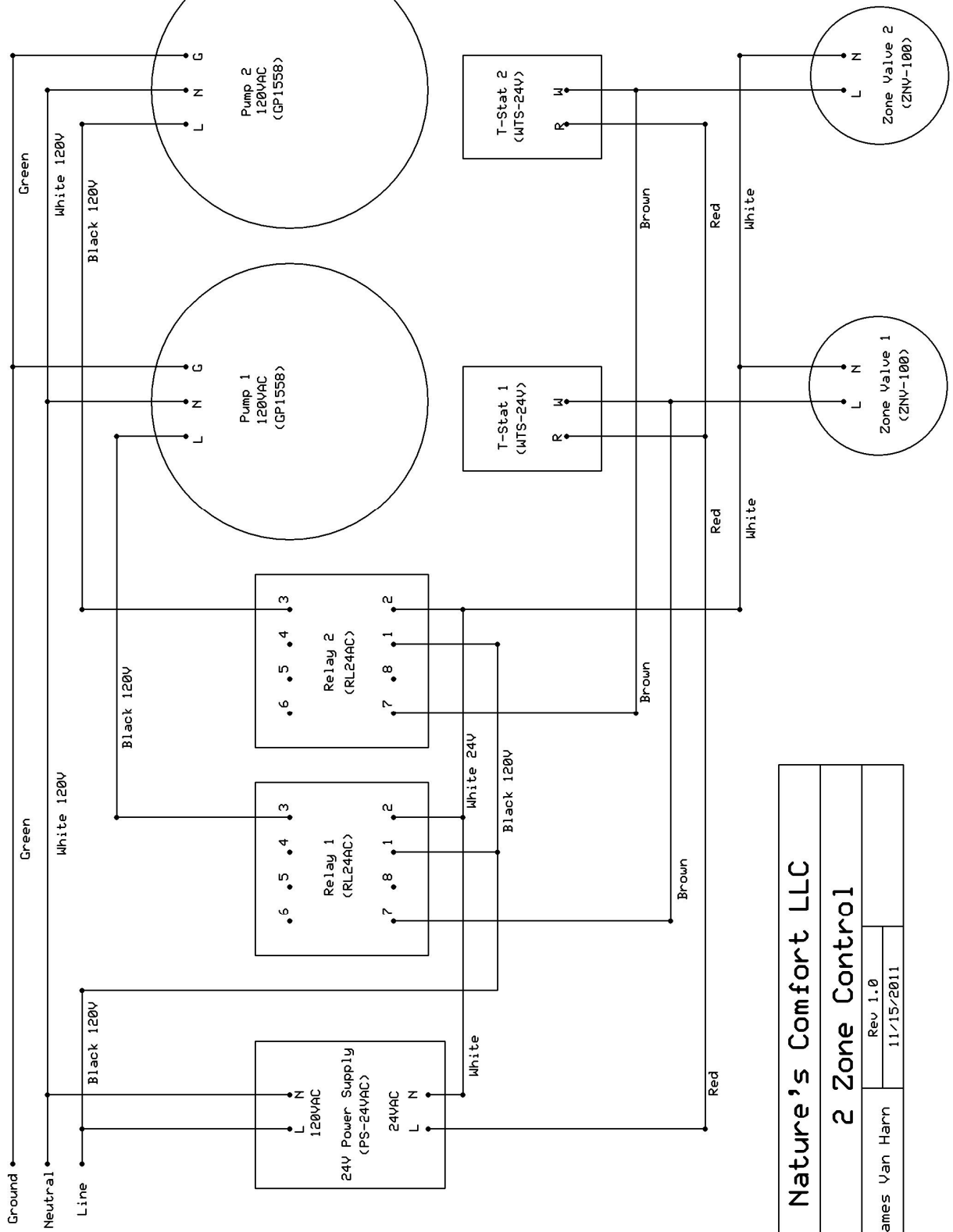

Nature's Comfort LLC	
2 Zone Control	
James Van Harn	Rev 1.0 11/15/2011

L. Filling the Boiler with Water

Inspection: Before filling, inspect the pump shaft by removing the large silver screw to expose the top of the shaft and turn back and forth with a screw driver to make sure the shaft was not broken during shipping. **Broken shafts are not covered under warranty unless found and noted before installation and startup. Also read maintenance section in full.**

Once all piping connections are complete, flush about 20 gallons of water into the float stack and drain, repeating until it comes out clean. Close drain valve and pour Nature's Comfort boiler treatment in – **required for warranty**. Fill the boiler with a hose through the float stack or if you have installed a fill line, open the valve and allow it to fill, stopping once the float starts to rise.

Use water that is softened and has low iron content if possible for maximum boiler and pump life.

Do not start circulation pump until boiler is FULL and the impeller and bearings have been primed! After filling, remove the top screw on the pump until a steady stream of water flows and all air has been purged. Being a wet-rotor unit, if the pump runs dry at all, it will seize up as the bearings rely on lubrication from the water. **See maintenance section for full details on pump operation and care.**

During the first heating cycle the water might expand and overflow. This is normal and will occur anytime too much water has been added. Open the drain valve to keep the float indicator at the bottom of the rubber cap. Any higher than this and hot water may push the float out and also cause scalding water to spill out. (Over-fill when boiler is shut off and not in use)

After water has circulated for 1 hour, test Nitrite level to assure required 1,000-1,500ppm and add treatment if below this level. Submit a water sample to your dealer or Nature's Comfort for official warranty Nitrite testing and also once a year thereafter. REQUIRED! See warranty for full details.

M. Float Level

After priming and starting the circulation pump and bleeding the heat exchanger (see next section), let the boiler heat up and run for 24 hours then top off the water if needed. The ideal water level is at the beginning of a heating cycle for the level indicator to be at the bottom of the rubber cap. The water level will rise and fall during operation as water expands and contracts with temperature changes. Be sure to keep the boiler full of treated water at all times including through the summer as this will keep the boiler free from corrosion and when in use, from overheating causing circulation pump failure.

N. Bleeding the Heat Exchangers

With the pump running (prime and flush bearings first!), simply close a valve on the return side, hold for 1 second then open quickly. Repeat the procedure four times or until you cannot hear air rushing through the line.

O. Pre-conditioning Rope Seals

Option 1: (Good) Wet the rope seals with WD-40 before firing the boiler to keep prevent hardening from smoke and creosote and re-apply 1 or 2 times during the heating season or as needed.

Option 2: (Better) Purchase a tube of high temperature caulk from your dealer or Nature's Comfort and lay a bead of caulk on the impression of the door jamb in the rope seals, placing a 2" strip of wax paper over them. Over-extend the latch open and bounce the door/ash pan closed, then leave open to fully cure before starting a fire to get a custom seal. Once cured, wet the rope seals with WD-40 to prevent hardening from smoke and creosote and re-apply 1 or 2 times throughout the heating season or as needed.

Option 3: (Best but more hassle and messy) Purchase a tube of high temperature caulk from your dealer or Nature's Comfort and brush over the entire surface area of the rope seals to permanently seal out smoke and creosote. Place a 2" strip of wax paper over this. Over-extend the latch open and bounce the door/ash pan closed, then leave open to fully cure before starting a fire to get a custom, long term seal.

NOTE! Adjust fuel door if you ever see any amount of smoke. See maintenance section. Door adjustment is done at the factory but may be required again after installation and before starting a fire as the seals compress over time. **See maintenance section for complete adjustment and care instructions.**

III. Heating Domestic Water, Pools and Spa's

A. Sidearm or Plate Heat Exchanger For Domestic Hot Water

For a sidearm heat exchanger, the hot line from boiler must first go to the top side port. This creates twice the domestic water flow through the sidearm as opposed to coming in at the bottom side port. For the fastest recovery, install a small circulation pump on the domestic side that is controlled by a strap-on thermostat or thermal snap disc placed on bottom line on the domestic side. Hookups to the domestic side must be connected to the drain and pressure relief ports. **You cannot use a sidearm if the pressure relief port is on top of the water heater tank.** The domestic side will not thermal siphon properly and will frequently air lock as well.

Make sure to keep drain & pressure relief in service & purge all air from piping and sidearm or it will air lock.

The plate HX drawing shown is for a pre-heater setup. Leave utility energy on for this to maintain the water temperature. As water is used it will then be heated by the plate HX for unlimited hot water. You may also use a plate HX to bypass the water heater entirely for on-demand operation.

Always use a mixing valve to prevent scalding water temperatures.

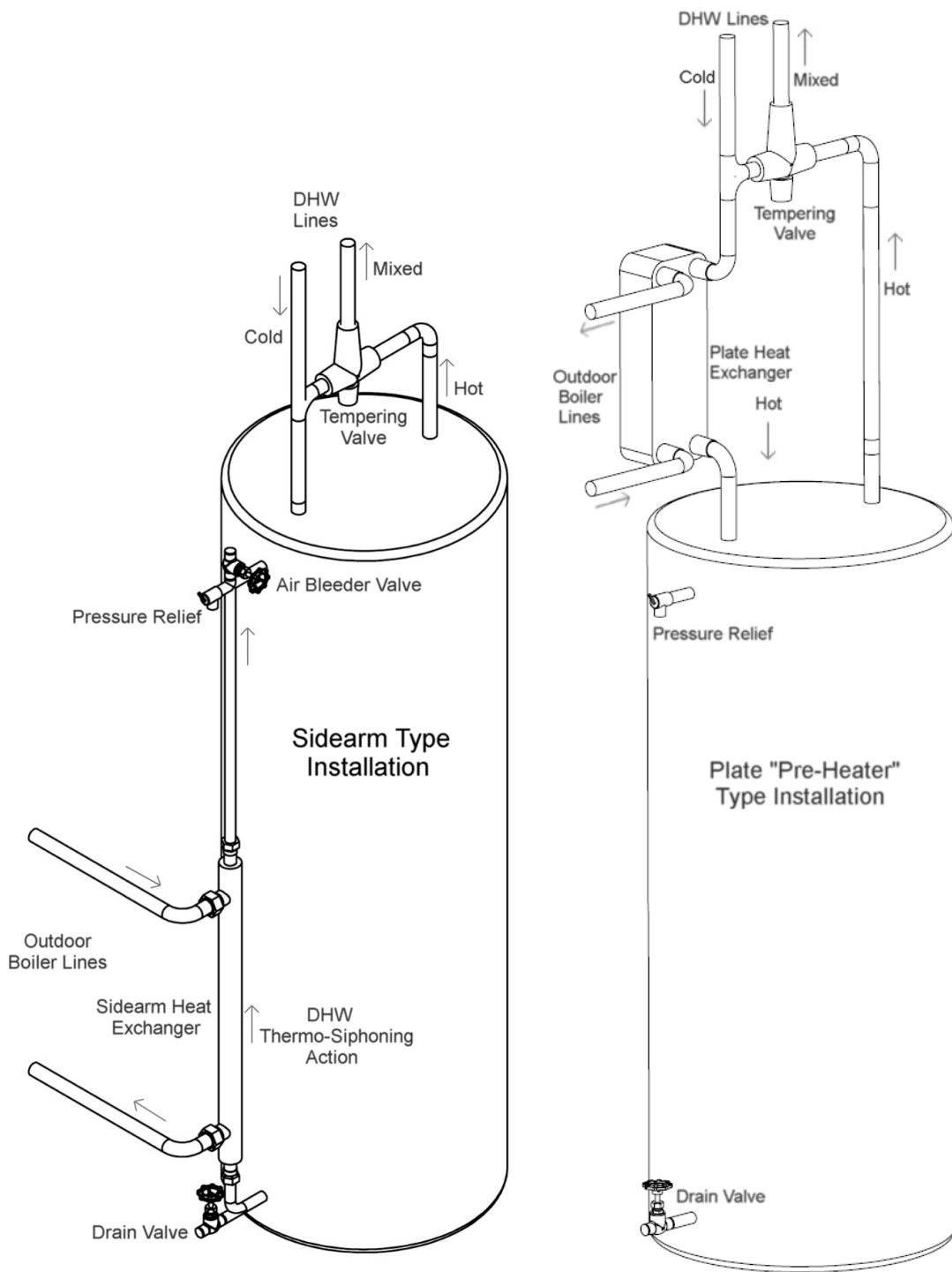

B. Heating a Pool or Spa

Please contact a local pool/spa specialist if this boiler is to be used to heat a pool or spa. A stainless steel (or 90/10 copper/nickel alloy) tube & shell water-to-water heat exchanger must be used to transfer heat from the boiler to a pool or spa since the chemicals used in a pool/spa are destructive to the boiler. Pool heat exchangers are available from Nature's Comfort or your dealer. For sizing you will need to know the volume of the pool in cubic feet or gallons. Be sure to install isolation and bypass valves for easy servicing and winter draining and also place before a chlorinator. Install a separate line and pump on the boiler that is controlled to only run when the pool filter pump runs.



IV. Operation

A. Coal Requirements

For maximum efficiency and burn times, only burn coal that has been sheltered from rain and snow. Burning wet coal is wasteful and inefficient. Water uses much of the combustion energy to dry out the excess moisture with extra smoke and creosote being created.

The coal should be no smaller than nut size otherwise it will drop through the shaker grates. **NOTE!** Nut coal requires that you remove the rubber intake flapper to have enough air during idling. Nut coal also requires small, more frequent loads in mild, warmer weather.

Stove size (slightly smaller than your fist) is ok but anything larger will not burn well, especially with a large heat demand as the total burning surface area of a load is less than if using smaller pieces.

Never burn driftwood, painted, stained or pressure treated wood. Do not burn trash, plastics, gasoline, rubber, naphtha, household garbage, material treated with petroleum products (particle board, railroad ties and pressure treated wood), leaves, paper products or cardboard.

Keep coal covered and store outside of clearance area listed on page 6. Moisture content from rain or snow will result in reduced burn times as heat will be used up drying out the moisture for the coal to burn.

B. Starting A Fire

Do not use combustible fluids or chemicals. Turn on the rear switch to run the blower. Use small pieces of split kindling together with crumbled newspaper and add larger pieces. Layer coal with coal to get the coal going and once visible burning, add a couple shovels full of coal. Do this 2 or 3 times and once fully burning, load the firebox up to the edge of the firebrick lined portion of the firebox (if applicable).

Caution! Follow procedures as outlined in “Loading Coal” (next section) for opening fuel door.

NOTE: There will also be a large amount of condensation created until the water jacket comes up to temperature. This may drip from access doors and covers and will dry out within 24 hours.

C. Loading Coal

Caution! Doors, covers, coals & ashes are hot! Wear safety glasses and use heavy gloves.

Caution! Never open fuel door without first turning off the boiler at the rear switch or flame spillage may occur!

Caution! Flammable gases fill the firebox when idling. Pause at blowback catch for 30 seconds and then stand to the side when fully opening until smoke dissipates enough to see inside. Failure to do this can result in possible flashback to the face from gases igniting.

Always stir ash to prevent “caking” before loading new coal. It is ok for some coals to drop through the slots in the floor as they will burn up. **Make sure slots in floor do not become jammed with coals or clogged with ash or operation will be affected.**

Load as quickly as possible, making sure you don't leave the door open long enough that would cause excessive heat and possible flames to exit the opening and damage the door jamb and unseal the caulking. If this starts to happen when loading, close the loading door to smolder down the fuel. Once the flames have died down (after several minutes), open the door again (pause at the blowback) and continue loading. Always add coal before the previous load has burned down to 25% of firebox capacity to have enough hot coals to ignite the next load of coal and make sure to first shake the ashes out of the coal bed before loading new fuel.

Most often the boiler can be loaded in the morning and at night. Burn times vary from 6-24 hours depending on fuel being used (soft coal and/or higher moisture content will require more frequent loading), installation, temperatures maintained and size of area being heated. Nature's Comfort makes no guarantees on burn times as there are too many variables outside of its control.

D. Blower Output Damper

The output damper on the flange where the blower is mounted is for adjusting airflow to obtain maximum burn times. Start with the damper pushed in and pull to open further as needed. Do not open so far as to throw embers out the chimney. The damper position will vary based on type of coal used and moisture content. If burning hard coal you may need to completely remove the damper to allow for a slight draft to prevent loss of combustion.

E. Power Loss, Running On A Generator

The controls are designed for the control plug to be used on a generator or vehicle inverter if needed. If the water jacket ever starts to overheat from lack of circulation during a power outage, first make sure to keep the water level full then use this feature to keep the pump running.

F. Warm Weather Operation, Bypass For Domestic Hot Water Only

Operation in warmer weather will result in larger amounts of creosote due to longer idle times and can also be more difficult as too many coals may cause the water jacket to boil if not enough heat is pulled from the water to heat the home. Use smaller loads of coal if this happens. Adequate water circulation is critical for preventing water from boiling. Also make sure all rope seals are properly sealed to prevent any extra air from feeding the fire. See the maintenance section for how to adjust door seals.

For heating of domestic hot water without heating the home, install a 3-valve bypass system shown in the next figure (shown on a water-to-air heat exchanger). This permits use of the boiler during the spring, summer and fall seasons to heat domestic hot water when heating the home may not be needed or wanted. Use of union fittings between the isolation valves and the heat exchanger for easy removal is recommended.

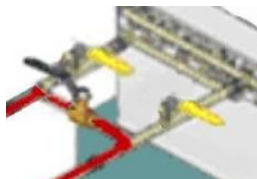

V. Maintenance

A. Cleaning

Wear heavy gloves and clothing and safety glasses as metal, coals and ashes will be hot.

Moisture combined with ash will eat through a boiler in short order and ash corrosion is NOT covered under warranty.

Clean ash out frequently and stir (break up) ash in ALL areas (especially corners) daily to prevent any “caking” (dense, compacted pockets most often occurring in corners). Caked up ash holds in moisture and failure to stir ash daily is one of the largest reasons for leaks in any coal boiler (along with lack of treatment) and neither are covered under warranty.

Caution! Follow procedures as outlined in “Loading Coal” (previous section) for opening the fuel door.

Close all doors and covers securely once cleaned and follow the procedure in the “Starting A Fire” section to re-start the boiler if needed.

B. Disposal Of Ashes

Ashes should be placed in a metal container with a tight-fitting lid. The closed container of ashes should be placed on a noncombustible floor or on the ground, well away from all combustible materials, pending final disposal. If the ashes are disposed of by burial in the soil or otherwise locally dispersed, they should be retained in the closed container until all cinders have thoroughly cooled. Other waste shall not be placed in this container.

C. Creosote - Formation And Need For Removal

When coal is burned slowly, it produces tar and other organic vapors, which combine with expelled moisture to form creosote. The creosote vapors condense and accumulate in the relatively cool chimney flue of a slow-burning fire. As a result, creosote residue accumulates on the flue lining. When ignited this creosote makes an extremely hot fire.

The chimney and any connectors must be inspected at least twice monthly during the heating season to determine if a creosote buildup has occurred. If creosote has accumulated (3mm or more) it should be removed to reduce the risk of a chimney fire.

Smaller, more frequent loading and dry, seasoned coal will help limit this. A small and intense fire is preferable to a large smoldering one to reduce the amount of creosote deposition.

If a soot or creosote fire occurs, keep all doors closed and run the boiler normally until all coal burns out then shut the boiler down and clean any soot or creosote deposits. Have a clearly understood plan to handle a chimney fire.

All creosote and ash must be cleaned from the entire boiler frequently as ash mixed with moisture is very corrosive and will shorten the life of the boiler if not maintained properly. Be aware that the hotter the fire, the less creosote is deposited, and that weekly cleanings can be necessary in mild weather, even though monthly cleanings can be enough in the coldest months. Check frequently for experience on how often cleaning is necessary (varies by operation, heating demand and coal quality). Creosote occurs on a larger scale when there is too much moisture content in the coal being used (green, un-seasoned coal) or from extended idling during milder weather.

D. Fuel Door And Ash Pan Seals

Caution! For inspection and adjustment, make sure to follow the same procedures for opening doors and covers as outlined for loading and cleaning.

Inspection

Check the rope seals on all doors and covers periodically during the heating season or when cleaning ash from the boiler as they will compress. **If any amount of smoke is seeping out, damage to a door or cover will occur if adjustment is not made immediately to tighten the rope seal. This is not covered under warranty.** Tighten/adjust whenever smoke is noticed seeping out or as needed using the procedures below. If there is no more adjustment available and smoke is seeping through, the rope seal must be removed, cleaned & loosened up, reversed and re-installed or replaced with new rope. Contact Nature's Comfort or your dealer for new rope or caulk if needed. This is a normal maintenance item and not a warranty issue.

Clean and coat entire threaded portion of all bolts for fuel door with a never-seize product if needed.

Adjusting Fuel Door

Slightly loosen one bolt on the hinge or latch (depending on where adjustment is needed) and tap with a coal block to re-position and then tighten. Continue with other bolts one at a time as needed. If the latch has no remaining adjustment, add washers behind the door handle to further tighten the latch side.

Installing Rope Seal (1" round rope)

Re-position the door hinge and latch as far out as possible and install 1" round rope seal with a 1/2" bead of high temperature caulk behind it to glue the rope in place. Use a thicker layer of caulk where needed to push rope out for maximum adjustment. This method can accommodate up to a 1/2" of misalignment.

Make sure to push the rope to the outside of the corners to mate properly with the jamb (do not stretch the rope). Put some caulk on the joint ends after cutting the rope and make sure the ends are compressed or smoke will seep through. Over-extend the door latch open and bounce the door closed twice to custom fit the seal to the jamb. If there are thick spots of caulk keeping the rope pushed out, leave door open 24 hours until caulk behind rope is fully cured. Re-adjust door to properly seal.

Pre-condition rope as explained in the "Installation" section. Start the boiler and tighten further if needed.

E. Pump

It is highly recommended that an additional pump or replacement cartridge be purchased from Nature's Comfort or your dealer to have as a spare.

Water: Since water quality characteristics greatly vary across the USA, some customers get much longer life out of a pump than others. Filling a boiler with softened water, adding and maintaining treatment so there's 1,000-1,500ppm of nitrites is the best thing you can do for pump and boiler life. While there is a one year warranty on our pumps (from customer's date of purchase), they must first be inspected and an attempt made to clean and put back in service before a pump or cartridge is determined to be "failed". Proper treatment and records must also be present for the warranty to be honored. If a customer had a water test pass but adds water frequently due to boiling or over-filling from improper operation this will bring down treatment levels quickly, possibly below the minimum level of 1,000ppm and void the boiler warranty.

The pump that comes with the boiler is a cost-effective, entry-level pump that performs excellent for most applications and water characteristics. A higher-end pump may be required if an application or water quality is too aggressive (i.e. Armstrong's E9.2 with a mechanical seal available from Nature's Comfort or your dealer. Other options also available)

Inspection: Before installing, inspect the pump shaft by removing the large silver screw to expose the top of the shaft and turn back and forth with a screw driver to make sure the shaft was not broken during shipping. **Broken shafts are not covered under warranty unless found and noted before installation and startup.**

Startup: Make sure the lines are filled and prime the pump by cracking the upper pump flange to bleed the air out of the impeller and volute. **IMPORTANT: The large, silver bleeder screw must also be removed from the pump before running for the first time to bleed all air from the bearings or the pump warranty will be void.** After priming the pump, remove and leave the bleeder screw out, start the pump to finish bleeding all air out of the bearings, shut off the pump and re-install bleeder screw. The pump may now run. Always run at high speed for the best efficiency of the boiler and heat exchangers in the home.

Inspection & Maintenance: Loosen the bleeder screw once a week (less often as experience shows otherwise) to flush the bearings to maximize pump life, especially for system filled with poor quality water (high iron, hardness, total dissolved solids, etc). It is highly recommended that a customer have their own test kit to monitor treatment levels once a month and add if needed. If when getting a sample for a test if the water is not perfectly clear, the boiler needs to be shutdown, drained, flushed, re-filled & treated. Customers must still have a test done by their dealer or Nature's Comfort per the warranty with full details on our website (check annually):

<http://www.naturescomfortllc.com/boiler-warranty/>

To inspect the upper bearing and shaft, unplug the pump, close the valves on either side of the pump to isolate (one should always be field installed right before the return line enters the water jacket to be able to fully isolate the pump, lines and HX's) and remove the bleeder screw to look at the upper bearing to make sure it's not worn out causing the rotor to scrub on one side of the canister housing.

To inspect and clean the rotor and canister, take the 4 Allen screws off to remove the motor from the volute. *****NOTE: The rotor shaft is ceramic. If it or the pump is dropped, hit, bounced or jarred it can fracture and/or break. Use care when handling.***** Gently use a screwdriver to pop the lower SS plate (also serves as the lower bearing) from the canister to pull the rotor out of the canister. Use a wire brush to clean off any scale buildup from the rotor. To remove the canister first remove the rotor, then tap on the bleeder screw to remove the canister from the motor (use this procedure for replacing the entire cartridge as well). White vinegar or a calcium and lime cleaner can assist for stubborn buildup. **Do not allow any liquids to enter the motor.**

Squealing: Comes from the bearings not having the air bled before running or not having enough clearance caused by scale buildup around the bearings or around the rotor inside the canister causing oscillation (vibration). Scale buildup happens if the water has too much hardness and is something that is greatly accelerated if the water does not have the proper amount of treatment. **Vibration can lead to fracturing and breaking of the shaft and is not covered under warranty.**

Scrubbing or ticking noise: Results from scale build up or the bearings and/or shaft wearing out allowing the rotor to come in contact with one side of the canister. All eventually lead to "seizing" up. Not bleeding air from the bearings, improperly treated water and/or high mineral content (hardness is the biggest problem) and TDS (total dissolved solids) that are abrasive all result in premature wear of the bearings or scale buildup.

F. End Of Season Care

- 1. Power:** Turn off power and switches and unplug pumps and control plug.
- 2. Chimney:** Inspect & Clean. Cap the chimney to keep rain water out, re-seal caulk.
- 3. Cleaning:** Perform a heavy cleaning and also completely remove all soot and hardened deposits using a putty knife and wire brush. Completely coat the steel inside all areas of the boiler with WD40 or a light coat of motor oil using a brush or rag to protect from rust during the off-season.

- 4. Doors & Covers:** Oil all door hinges and latches. Re-condition rope seals if needed. Re-seal caulk on all jambs. Coat entire threaded portion of all bolts for doors and covers with a never-seize product.
- 5. Plumbing:** Ensure fittings are tight at all locations.
- 6. Water Jacket:** Over-fill so float pointer is 4" above rubber cap, re-seal caulk.
- 7. Pump:** Remove bleeder screw and flush, inspect and turn shaft with screwdriver. See maintenance section for further details.
- 8. Water Treatment:** Make sure water is tested and has enough Nature's Comfort water treatment. See warranty for further details.
- 9. Misc:** Sand and paint any rust.

Moisture from condensation or rain must not be allowed to accumulate in the firebox or ash pan during the off-season. Failure to perform preventive maintenance may result in severe corrosion and major damage to the boiler. This is not covered under warranty.

Going Away

When going away during freezing weather and no one will be keeping the boiler going, turn the rear control switch off and keep the circulation pump running and turn the backup heat system on. The boiler will now operate in reverse heat being kept above freezing by the backup system eliminating the need to otherwise drain the boiler, invest in anti-freeze or find someone to load coal.

Please keep this manual with all other important papers. The information in this manual is necessary for the installation, operation and proper use of the boiler. If you should ever have a problem or question refer to this manual or call your dealer. If your dealer does not have the information you need, request they contact Nature's Comfort and your dealer will be further educated to provide the best possible customer service. Please keep in mind that Nature's Comfort built the boiler but did not install it and has no control over the installation, operation, efficiency of the building's insulation or what is burned in the boiler.

Disclaimer

All installation and operation must follow Federal, Provincial, State and Local codes, ordinances and laws.

Nature's Comfort boilers are not intended to be used in urban areas.

Nature's Comfort boilers are not intended to be the only source of heat. A backup system should always be in place and ready for use.

Nature's Comfort boilers are not intended to and must not operate under pressure.

All electrical and plumbing should be done by qualified personnel and conform to national, state and local electrical, plumbing, fire and building codes.

Manufacturer is not liable for damages to personnel or property for misuse, improper installation of equipment or for knowing Federal, Provincial, State and Local codes, ordinances and laws including local installation codes. Owner assumes all responsibility for this.

See warranty for further details.

Trouble Shooting

Problem	Cause	Solution
Boiler does not come up to temperature.	Improper or wet coal is being used Wind blowing under boiler	Use properly sized, dry coal Take one or two inches of hard board insulation and place under boiler between legs then add non-combustible spacers between ground to hold up insulation
The boiler is at temperature and is steaming	Poor water circulation (excess fittings, pump or pipe too small, improper installation)	Change to a larger pump, use min 1" pipe and sweeping bends instead of 90's
Poor burn time	Improper or wet coal is being used Too much demand on unit, undersized for application	Use properly sized, dry coal Lower home temperature set points, insulate home better, upgrade to larger boiler
Boiler is up to temperature but little to no heat in house	Poor circulation (A simple test can be done to determine if this is so: touch the pex line leaving and returning to boiler. There should be little or no temperature difference) Heat exchanger plugged Improperly designed installation Not enough insulation in building	Change to a larger pump Clean with white vinegar – be sure to use NC boiler treatment to prevent this Use min 1" pipe, reduce number of 90's & T's used, re-route lines Add insulation to structure
Boiler over heats	Air leak Blower output damper open too far Poor circulation Water is low in boiler Aqua-stat malfunction Not enough demand &/or warm weather	Make sure doors and covers are sealed & adjust if necessary Adjust damper Larger pump or pipe, reduce # of fittings Add water to keep full Replace aqua-stat Load smaller amounts to prevent large coal bed from over-producing
Boiler fire does not stay lit	Not leaving some coals in burn area No air flow Chimney plugged with creosote	Load sooner to have more coals Check the area behind the ash pan to make sure there is no ash build up that would block blower air way, replace blower Clean chimney and extensions/cap
Good coal but does not burn. Only smolders	Holes in floor plugged Solenoid failed Blower failed	Completely clean ash from all areas of boiler Check controls, replace failed component
Boiler up to temperature but no heat in house	Circulation pump failed	See maintenance section on "pump"
Boiler water getting rusty	Not enough or no boiler treatment	Have your water tested. Boiler treatment is required for warranty to be valid. See warranty.
Blower turns on but solenoid doesn't open damper	Loose electrical connection Solenoid failed	Turn power off and check all wire connections Replace solenoid
Water leaking from boiler	Condensation from first start-up of boiler Condensation from wet coal Condensation from running below 150F	Wait 24 hours to heat up and dry out Burn only seasoned hardcoal Adjust aquastat to 165-180 with a 15 degree differential
Aquastat calling for heat but unit not running	Control switch is off Failed aquastat	Turn on switch Replace aquastat

20 Year Limited Warranty

Nature's Comfort LLC, of Shipshewana, IN 46565 warrants material and labor on any defects in workmanship on the fire drum for a period of 20 years from the purchase date to the original owner only (see proration below) and on the water jacket for a period of 10 years from the purchase date to the original owner only (see proration below). If there is a leak in your properly delivered, installed and maintained Nature's Comfort boiler, we will cover repair costs for the first 5 years and prorated after that (see below). Repair can be denied if the unit's water jacket has exceeded 220 degrees. The aquastat must be set so the water jacket temperature never falls below 150F otherwise condensation will be created on the inside of the firebox and will cause corrosion that is not covered under warranty.

This warranty is limited to defective parts and excludes any incidental and consequential damages connected therewith. Nature's Comfort does not warranty damage or malfunction to any interior portion of the boiler caused by ash corrosion or allowing the unit to overheat. All interior portions (especially corners) must have the ash stirred daily to prevent caking and be completely cleaned out of all ashes and creosote a minimum of 2 times per year, half way through the heating season and at the end of heating season. The chimney must be covered or have a rain cap when the boiler is not in use. Caulk around chimney and float stack must be inspected frequently and re-sealed if necessary. Caulk sealant and rope gaskets are not covered under this warranty. Damage caused by abuse, neglect, accidents, improper installation, customer or dealer modification, overheating and/or freezing will not be covered under warranty. Damage caused by burning flammable materials (i.e. petroleum products), wet coal or anything other than dry soft or hard coal will not be covered under warranty. Nature's Comfort does not warranty boilers against environmental conditions out of its control. Nature's Comfort does not warranty or guarantee against your area's governing laws or changes in your area's governing laws that will affect the use or non-use of the unit.

Nature's Comfort is not responsible for replacement of water, water treatment, antifreeze and glycol, costs of transportation or shipping charges. On sight non-warranty parts and labor will be provided at the discretion of your dealer. Please contact your dealer for their current non-warranty rates. Labor is not covered for repairing or replacing electrical or other components not a part of the welded assembly that is under warranty.

Nature's Comfort's coal boilers are not meant to be your sole source of heat. It is the responsibility of the owner to have a backup system in place. If you do not have a backup source of heat you are at risk of damage due to lack of heat. Nature's Comfort will not warranty or be responsible for any damage caused by lack of heat at your premises or for any cost incurred from using a backup heat system in the event of a boiler failure.

There is no written or implied performance warranty on the boiler as Nature's Comfort has no control over the installation, structure insulation, maintenance, daily operation and heating demand on a unit or what is burned in the boiler. Nature's Comfort will not cover or be held responsible for any cost of coal burned in excess of what is expected or considered normal as installation, fuel being used, structure size and insulation conditions are out of its control.

Treatment & Testing

Your boiler must have "Nature's Comfort Boiler Treatment" added during initial filling with water, antifreeze or glycol and a water sample must be submitted for nitrite testing when first filled and then annually at the end of a heating season to ensure proper nitrite concentration (1,000-1,500ppm) for your warranty to remain valid. The water jacket must remain full of properly treated water at all times after installation save for draining, flushing and re-treating. Minimum recommended initial mix ratios for each boiler is (an officially approved nitrite test must still be performed after treating): NCB120COAL - 1.5Qt; NCB175COAL - 1.5Qts; NCB250COAL - 2Qts; NCB325GCOAL - 3Qts. Contact Nature's Comfort or your dealer to obtain water treatment. You must have your water tested for nitrites by your dealer or Nature's Comfort (\$10). Always request results to be sent to you and you must keep them on file to show proof of treatment and testing if warranty work is ever needed. Testing done by anyone other than a dealer, a certified lab or Nature's Comfort will not be accepted for warranty claims but is encouraged for monitoring treatment levels to obtain the maximum life out of a Nature's Comfort boiler, particularly if water is being added throughout a heating season (this is a result of improper operation or installation). Drain, flush, re-fill and re-treat if water is ever not crystal clear. Treatment and nitrite test kits are available from your dealer or Nature's Comfort.

NOTE! Visit www.naturescomfortllc.com/warranty each year to confirm current treatment and testing requirements and to download a water test request form to send in with a water sample.

Nature's Comfort On-Site Warranty Proration:

Nature's Comfort will pay costs of warranty work based on the following proration:

Fire Drum: Years 1 - 5: 100%, Year 6 - 90%, Year 7 - 80%, Year 8 - 70%, Year 9 - 60%, Year 10 - 50%, Year 11 - 40%, Year's 12 - 14: 30%, Years 15-20: 20%

Water Jacket: Years 1 - 5: 100% Year 6 - 80%, Year 7- 60%, Year 8 - 40%, Year 9 - 20%, Year 10 - 10%

1 Year Warranty on Other Components

Nature's Comfort warranties, to the original owner only, any component a part of the boiler that is defective during normal usage for a period of 1 year from customer's date of purchase. Shipping for returning defective parts is not included. Replacement/repairs are obtained from the dealer purchase was made through. Labor is not covered for repairing or replacing components that is under warranty. After one year, your dealer may charge you for any parts provided. No warranty parts will be provided without first returning the defective part. Replacement/repairs carry a 90 day warranty or the fulfillment of the 1 year warranty period, whichever comes later. Pump failure due to water quality issues or not bleeding the air out from the bearings before startup are not covered under warranty. Proof of treatment and testing is required for pump warranty.

Warranty Procedure

All claims under this warranty must be made through the dealer where the boiler was purchased. If an inspection by the dealer indicates that a warranty claim is justified and that all conditions of this warranty have been met, Nature's Comfort will repair or replace the problem part according to the above proration. Proof of purchase, treatment and testing records and return of the defective part (if applicable) must be provided by the owner of the boiler before any warranty is given. All costs of removal, shipment to and from the dealer or Nature's Comfort and losses during shipment and reinstallation and any other losses due to the stove being removed shall be covered by the owner of the boiler. If your dealer no longer exists, please contact Nature's Comfort via email: warranty@naturescomfortllc.com. It may be necessary for you to obtain quotes from one or more local professionals and to email pictures of an issue.

This warranty is subject to change without notification. Visit www.naturescomfortllc.com every year to confirm current warranty and installation information or call your dealer.

Customer Warranty Card

Please fill in the following information and keep for future reference.

Name: _____
(First) (Last)

Address: _____
(Street)

(City) (State) (Zip)

Phone: _____
(Area Code) (Number)

Model & Serial Number: _____

Date of Purchase: _____

Dealer Purchased From: _____
(Business & name) (Phone number)

Date of Installation: _____

Installed By: _____
(name) (Phone number)

Retain this copy for your records.

Please keep this manual with all other important papers. The information in this manual is necessary for the installation, operation and proper use of the boiler. If you should ever have a problem or question refer to this manual or call your dealer. If your dealer does not have the information you need, request they contact Nature's Comfort and your dealer will be further educated to provide the best possible customer service. Please keep in mind that Nature's Comfort built the boiler but did not install it and has no control over the installation, the efficiency of the building's insulation or what is burned in the boiler.

Water Treatment

Make sure the water is tested by an approved 3rd party to have the required concentration of Nature's Comfort boiler treatment (1,000-1,500ppm of nitrite) so there will be no rust or corrosion. This is required to keep the warranty valid. Please see warranty page for further details and instructions on treating and having the water tested.

Check here for each year tested for your records:

Year 1__ 2__ 3__ 4__ 5__ 6__ 7__ 8__ 9__ 10__ 11__ 12__ 13__ 14__ 15__ 16__ 17__ 18__ 19__ 20__
21__ 22__ 23__ 24__ 25__ 26__ 27__ 28__ 29__ 30__ 31__ 32__ 33__ 34__ 35__ 36__ 37__ 38__

Mail-in Warranty Card (information is never shared or sold)

All fields must be filled out

Name: _____
(First) (Middle) (Last)

Address: _____
(Street)

(City) (State) (Zip)

Phone Number: _____
(Area code) (Number)

E-mail Address: _____
(For contact purposes only)

Model & Serial Number: _____

Date of Purchase: _____

Dealer Purchased From: _____
(Business and first/last name)

Date of Installation: _____

(In case of questions)

Installed By: _____
(Business and first/last name)

Installer's Address: _____
(Street)

(City) (State) (Zip)

Installer's Phone Number: _____
(Area code) (Number)

How did you hear about Nature's Comfort?

___ Flyer ___ Auto RV Magazine ___ Internet Search Engine

___ Other Magazine (Specify) _____

___ Dealer ___ Friend or family ___ Other (Specify) _____

Mail, Email or Fax To:

Nature's Comfort LLC
3790 N SR 5
Shipshewana, IN 46565
warranty@naturescomfortllc.com
866-222-8702